

HPI wants to thank you for your confidence in its products.
 Please read this manual carefully to ensure years of enjoyment of this specialised high end electronic device.
 This manual shows you how to properly install the stator, rotor, CDI and HT coil.

Rotor - stator installation using the analogue 068C002 CDI:

The rotor has to be placed on the crankshaft or on an axis which rotates at the same speed.

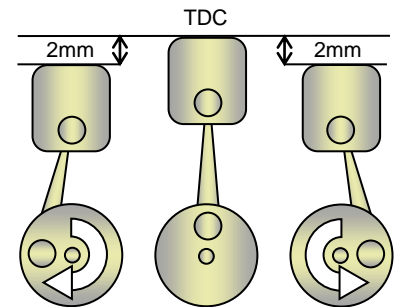

- Remove the original ignition from your engine.
- Re-tap the 3 English threaded holes to M8.
- Adjust the height of the stator plate with the included spacers.
- Locate the cable exit on your engine and position the stator according to this hole. If necessary, remove the plug (see backside) and lead the cable through the hole.
- Centre the stator on your engine.
- Gently bolt the stator to your engine; do not tighten the bolts yet.
- Turn the shaft to position the cylinder 2mm before its Top Dead Centre (TDC).
- Place the rotor on the shaft, aligning the mark on the rotor with the mark on the stator. **Mind the position of the HPI logo**; take the 2nd large marking, according the rotation direction. (See images below)
- This position corresponds with the set point in the ignition curve. (see backside image)
- Fasten the rotor to the shaft. If necessary, remove the stator to have a good grip on the rotor.
- Remount the stator and recheck the position of the cylinder with a micrometer.
- If necessary, realign the markings by turning the stator plate.
- Fasten the stator plate.

To gain performance, try to vary the cylinder position between 2 to 4mm before TDC, by turning the stator plate.

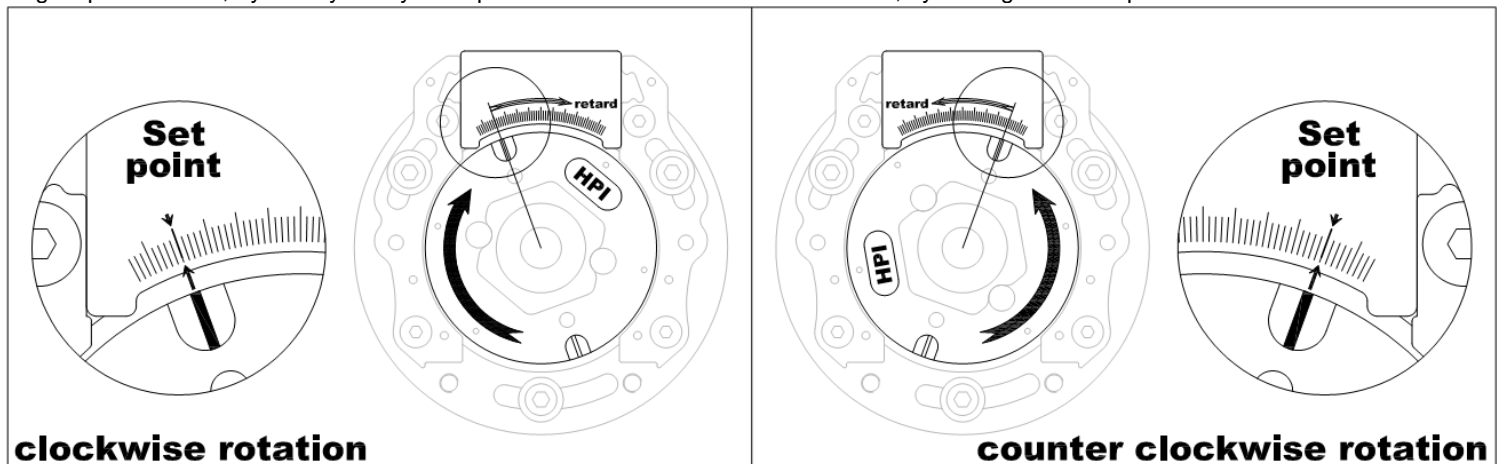

Analogue ignition curve:

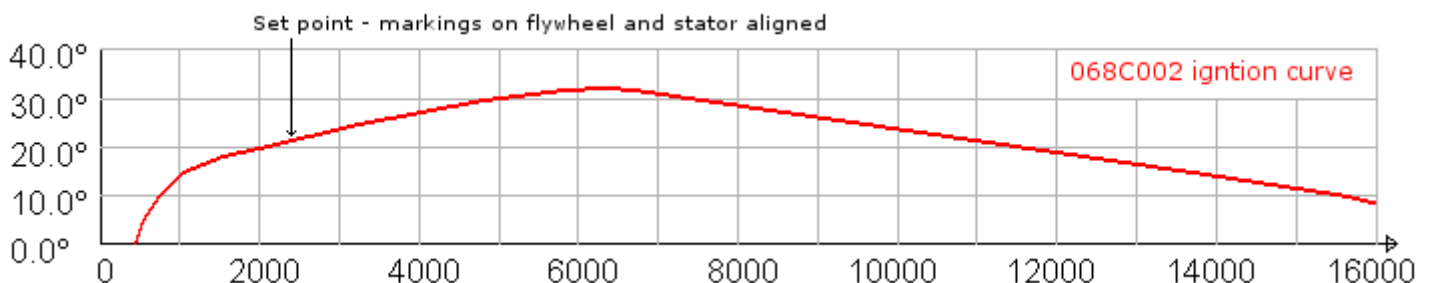

Wiring instructions:

- **HT-coil** orange black ring Connect the HT-coil to the frame. Plug the orange cable to the HT-coil, Connect the black cable with ring to the bracket of the HT-coil and to the frame.
- **Stator** 3-way plug Plug the 3-way connector of the stator directly into the CDI. If you need to lead the cable through a narrow hole; see back side to remove the plug from the cable.
- **Kill** black/white Connect the black-white to frame / ground for an emergency stop.

Rotor - stator installation for the digital 068C041 CDI:

The rotor has to be placed on the crankshaft or on an axis which rotates at the same speed.

- Remove the original ignition from your engine.
- Re-tap the 3 English threaded holes to M8.
- Adjust the height of the stator plate with the included spacers.
- Locate the cable exit on your engine and position the stator according to this hole. If necessary, remove the plug (see backside) and lead the cable through the hole.
- Centre the stator on your engine.
- Gently bolt the stator to your engine; do not tighten the bolts yet.
- Turn the shaft to position the cylinder in its Top Dead Centre (TDC).
- Place the rotor on the shaft, aligning the mark on the rotor with the corner of the stator cover.
- **Mind the position of the HPI logo.** (See images below)
- This position corresponds with 0° in the ignition curve and with 0° in the TuneBox software. (see backside image)
- Fasten the rotor to the shaft. If necessary, remove the stator to have a good grip on the rotor.
- Remount the stator and recheck the position of the cylinder with a micrometer.
- If necessary, realign the rotor marking with the corner of the stator cover by turning the stator plate.
- Fasten the stator plate.

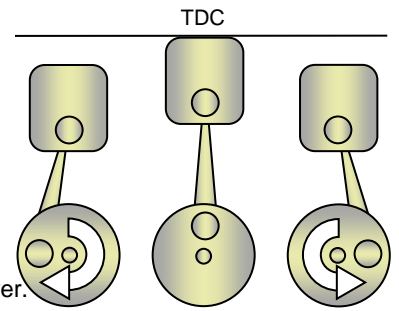

To gain performance, try to change the ignition curves using the TuneBox software.

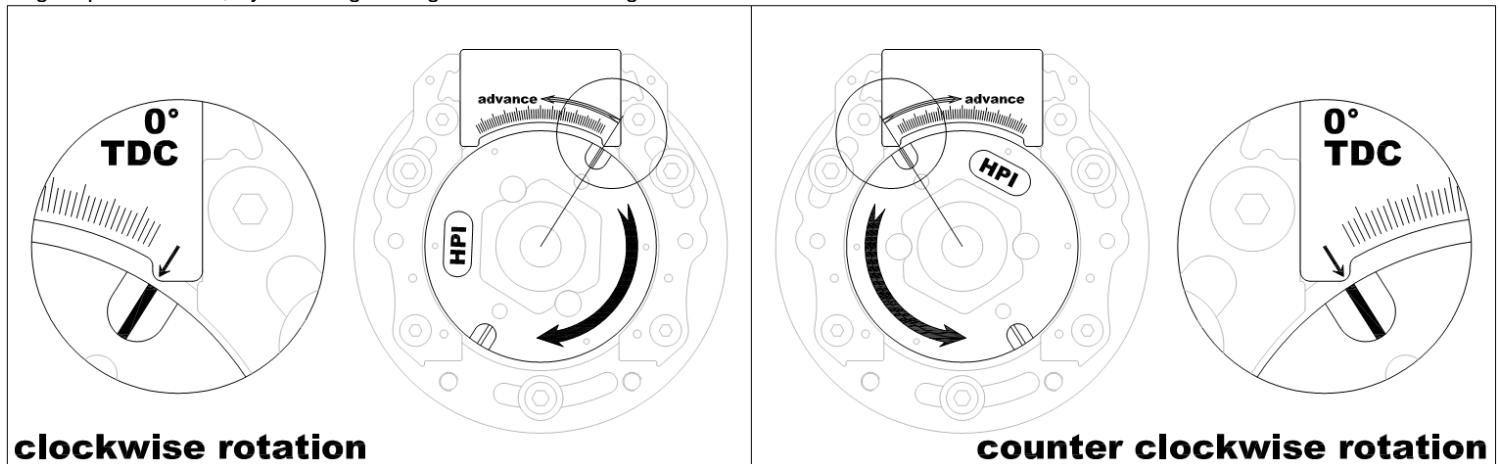

Digital ignition curves – adjustable with TuneBox software:

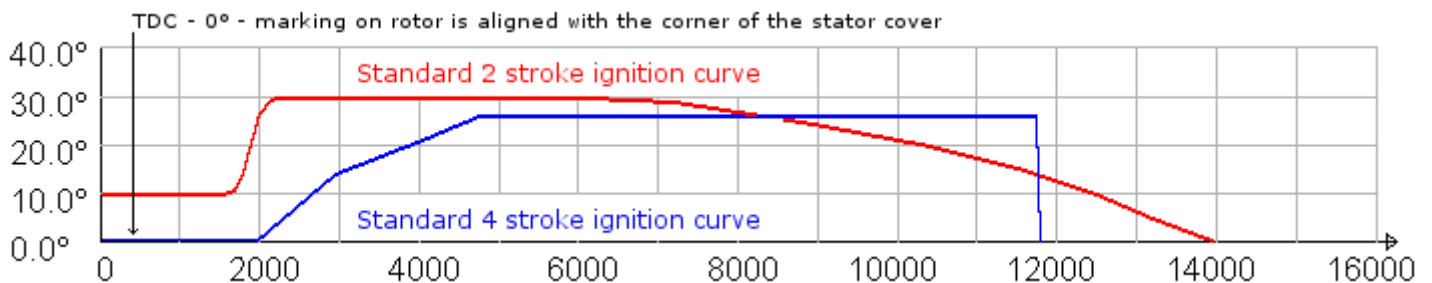

WARNING

This is a digital CDI. Use resistive spark plugs and spark plug caps. (typical $5K\Omega$)

Wiring instructions:

- **HT-coil** orange
black ring Connect the HT-coil to the frame. Plug the orange cable to the HT-coil, Connect the black cable with ring to the bracket of the HT-coil and to the frame.
- **Stator** 3-way plug Plug the 3-way connector of the stator directly into the CDI. If you need to lead the cable through a narrow hole; see back side to remove the plug from the cable.
- **Kill** black/white Connect the black-white to frame / ground for an emergency stop.

Remarks:

- The CDI-unit and cables must not be exposed to **mechanical stress**.
- The CDI-unit must not be exposed to **excessive heat** (not behind the radiator, close to the cylinder or the exhaust).
- The CDI-unit must not be exposed to **electrical interferences** (not close to the ht-coil).
- The CDI-unit must not be directly exposed to **fluids** (water, gasoline, oil,...).
- **Do NOT** extend cables, this may cause interference and damage to the CDI or the engine.

Optional Parts:

► Flywheel puller – 068V262 ◀

To easily remove the rotor, HPI can provide you with a puller. This is a widely applicable flywheel puller.



► Inertia disk – 068V101 ◀

If your engine requires a heavier flywheel, you can add an inertia disk to the 068 ignition. The inertia disk is a stainless steel disk of 95mm diameter, 300 grams, specially designed to centre-fit on the 068 rotor.



► Tacho output ◀

Connect the red cable of the CDI with the input of your tacho.

► Curve switch – 068V064 ◀

For 2-curve CDI units (optional), the curve select button comes in handy. It is easy mountable on your handle bar. Makes or breaks the connection between the yellow and yellow blue cables.



► Light coil – 068V024 ◀

This coil will enable you to run lights on the 068 ignition. The coil however will only deliver 10W of power at 12V. Take a look at our 210 ignition range, which has a 60W power output.



► YPVS output ◀

Connect the yellow-black output of the CDI to the input of the YPVS steering box and the tacho.

► Fan blade adaptor – 068V075 ◀

Mount different fan blades and water pump actuators to the 068 ignition.



► TuneBox software – 068V043 ◀

With a digital CDI (optional), the TuneBox software and interface, you will be able to get the maximum performance of your engine. Design your own ignition curves, set **rev limiters**, drive a **power jet** exit and set the optimum **quick shift** timing for your engine, it's all possible with TuneBox.



► AETC ◀

Connect the white-blue output of the CDI with the input of the AETC steering box.

Connector removal:

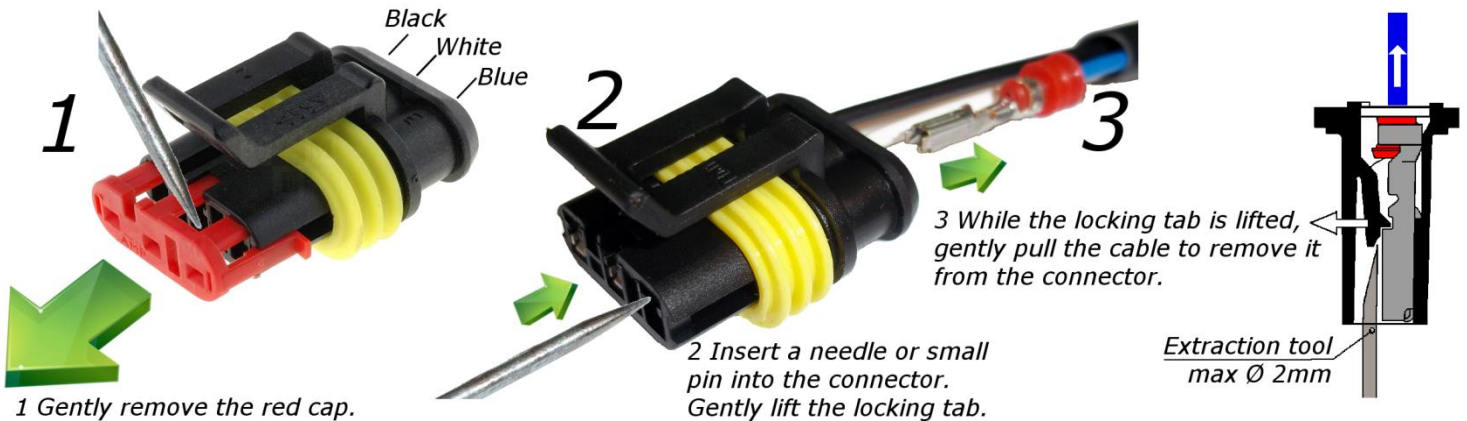

To reassemble the plug, insert the terminals back in place till the locking tab clicks in and put back the red cap.